

HullVac pump corporation

HC Series 35 and 18 CFM Compound Stage Rotary Piston Vacuum Pumps

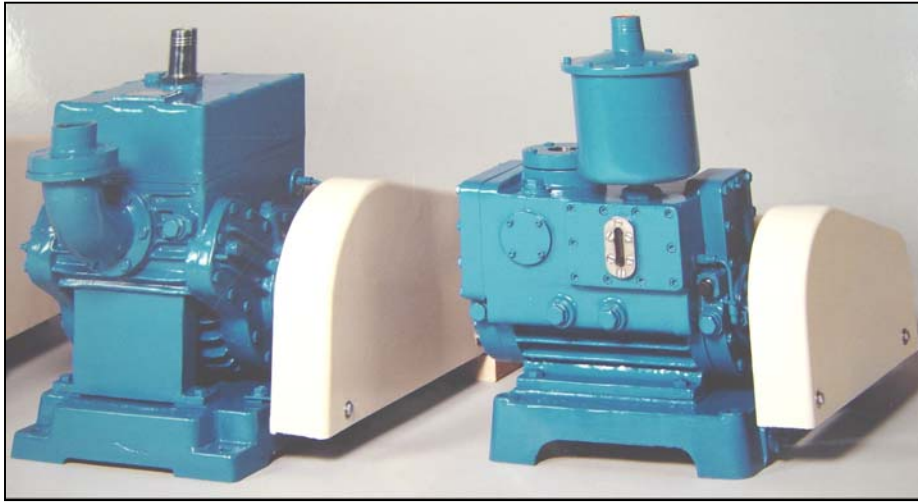

- ✓ Two-stage design assures high throughput below 300 microns
- ✓ Low blank-off to 0.001 Torr
- ✓ Low vibration
- ✓ Adjustable gas ballast handles condensable vapors
- ✓ No metal-to-metal contact in pumping chamber increases wear life.
- ✓ Air cooled designs for easy installation

Two Stage Performance at a Single Stage Price

Compound design combines performance with cost savings

Compound series pumps offer high efficiency pumping below 300 microns. They eliminate the need for blowers in some applications, thus reducing system complexity and cost. Replacing a single-stage pump with a compound increases vacuum system performance by reducing pump-down time and base pressure. When low base pressure is required, a less expensive, lower capacity compound pump can equal the performance of larger single-stage pumps.

In metallizing and drying applications with high water loads, micron range performance can still be achieved, even with full gas ballast. This feature prolongs the useful life of sealing fluids while maintaining superior vacuum pump performance.

Designed and built for durability

Constructed from chemical resistant cast iron, HC series pumps feature hardened shafts with Viton shaft seals. Our rotary piston design and low rotational speeds reduce wear.

Backed by value-added service and support

After the sales we provide long term value with our standard extended Three Year Limited Warranty and Uptime Program. Under the Uptime Program we ship you a loaner pump while your pump is at our facility for inspection or repair.

Specifications	HC-35	HC-18
Free Air Displacement (CFM)	35	18
Vacuum Stages	2	2
Ultimate Pressure	.0001 Torr	.0001 Torr
Ultimate Gas Ballast Pressure	.005 Torr	.005 Torr
Motor (HP)	3	1.5
Motor Voltage	208/230/460	208/230/460
Pump Operating Speed	510 RPM	610 RPM
Oil Capacity (Quarts)	2	1.75
Weight (Pounds)	320	260
Inlet Connection	1.5" NPT	1.25" NPT
Outlet Connection	1.25"NPT	1 inch Hose
Cooling	Air	Air

Dimensions

	HC-35	HC-18
B1	17.84	18.37
B2	13.58	14
B3	11.42	12
B4	1.13	1
B5	4.63	4
B6	-	10.75
H1	19.13	23.88
H2	16.5	14.75
L1	29.53	24.75
L2	27.36	22.37
L3	1.08	5
L4	6.59	3
L5	10.71	-
M	.63 Dia.	.63 Dia.

All dimensions in inches

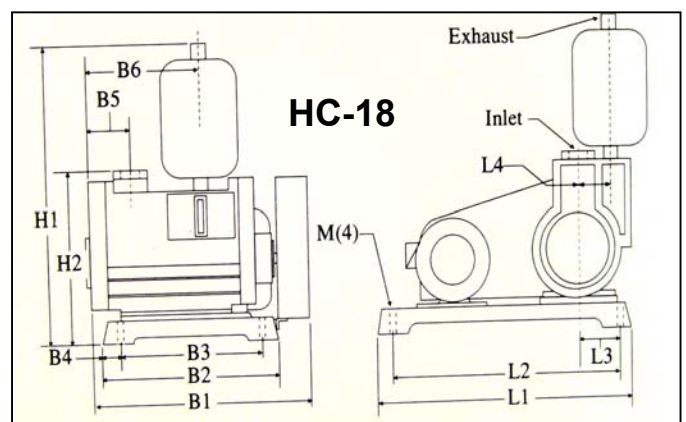
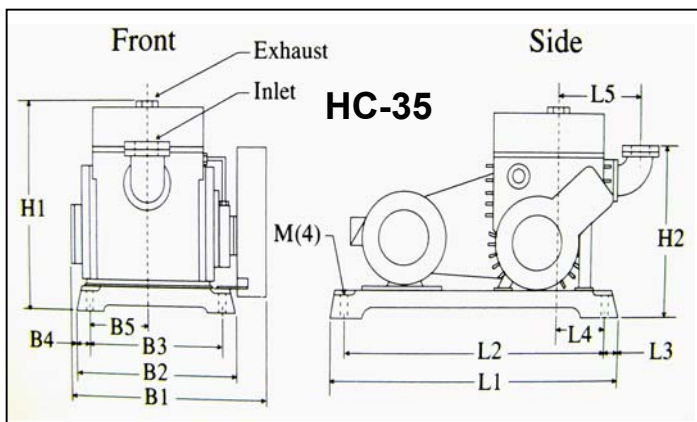
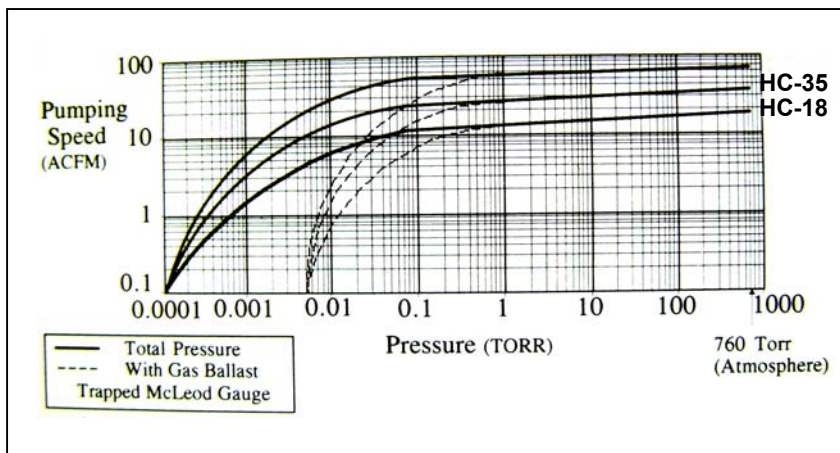

HullVac 73 Steamwhistle Drive
Ivyland, PA 18974-1451
215-355-3995 Fax 215-355-3994
pump corporation

www.hullvacpumps.com email: info@hullvacpumps.com